

**GRATON FIRE PROTECTION DISTRICT  
BOARD OF DIRECTORS  
BOARD MEETING AGENDA  
3750 Gravenstein Hwy N, Sebastopol, CA 95472  
December 8, 2020 7:00pm**

---

*Participate by phone (605) 475-4120, passcode 370238#*

---

1. Call to Order
2. Pledge of Allegiance
3. Roll Call
4. Corrections to the Agenda
5. Scheduled and Unscheduled Appearances. *During this period, the Board of Directors will hear anyone who desires to speak on subjects not listed on the Agenda. As a matter of policy, the Board will not make a decision unless it is of a routine nature, which may be turned over to staff for disposition. Please limit your comments to five (5) minutes and please state your name and address for the minutes (optional).*
6. Old Business
  - a. Terrorist Coverage
  - b. Review Strike Team Response SOG
  - c. Part Time Fire Chief Job Description
7. New Business
  - a. Policy Update – Cadet Job Description
  - b. Oath of Office – Reelected Board Directors
  - c. Board Positions
8. Committee Reports
  - a. Apparatus
9. Approval of prior Board Meeting Minutes
10. Purchase Requests
11. Bills & Warrants
12. Budget Report
  - a. Fiscal Year 19/20 Audit Report
13. Correspondence
  - a. Parcel Tax Exemption Request(s)
14. Fire Chief's Report
  - a. Roster, Alarms and Drills
15. Closed Session: Fire Chief Job Review: Government Code section 54957(b)(1)
16. Adjournment

**ADA Compliance**

*In compliance with Government Code 54954.2(a), the Graton Fire Department, will, on request, make this agenda available in appropriate alternative formats to persons with a disability, as required by the section 202 of the American Disabilities Acts of 1990 (42 U.S.C. 12132), and the federal rules and regulations adopted in implementation thereof. Individuals who need this agenda in an alternative format or who need a disability-related modification or accommodation in order to participate in the meeting should contact Board Recording Secretary, at (707) 823-8400 x107, 72 hours or more prior to the disability accommodations being needed in order to participate in the meeting.*

## Strike Team Responses

### 411.1 PURPOSE

With Chief Officer permission, the District will send resources outside of Sonoma County, either planned or immediate need. When outside the District, firefighters shall follow all policies, procedures, and SOGs as well as the Sonoma County Strike Team Code of Conduct.

Prior to fulfilling a strike team request, the Chief Officer shall ensure that the Graton Fire District is adequately covered while the strike team crew is out of County. This shall include, at a minimum, an on-call or in-house crew of two (2) firefighters with the ability to drive a type I engine.

Firefighters will be selected to participate on the strike team crew based on sharing availability on the strike team calendar. Strike team opportunities shall be offered and rotated to firefighters evenly. To be eligible, a firefighter must have a current "red card" which indicates completion of the necessary wildland training, both initial and annual refresher.

When there is sufficient coverage, strike team availability is posted every Sunday night on the Strike Team Availability web page. Availability is posted from Monday-Sunday.

To be eligible to deploy, firefighters must be available for a minimum of seven (7) days. Crews may be rotated out at any time after (7) days to be fair to those interested in participating on strike teams.

Personnel will be paid for strike teams based on the rates set by the District Policies & Procedures after receiving the approved paperwork from the State of California or Federal Government.



GRATON FIRE PROTECTION DISTRICT  
POLICIES AND PROCEDURES

TITLE: CADET

ADOPTED: 7/11/00

LAST REVISION 12/08/20

---

CADET

1. A Cadet shall be appointed by the Fire Chief after submitting a written application. Cadet must provide a current copy of a valid California driver's license or identification card and DMV printout if applicable, and vehicle insurance if applicable. A Cadet shall serve at the pleasure of the Fire Chief and may only be discharged by the Fire Chief.
2. A Cadet must be between the ages of 16 and 18 years of age.
3. A Cadet will submit a parental signed consent and waiver of liability agreement provided by the Department.
4. A Cadet will be a Member of the Department and will be identified ~~on as~~ a "Fire-Cadet" list, which will be kept separate from the Fire Volunteer Roster and will not be counted when determining the maximum allowed number of firefighters.
5. A Cadet will participate in a firefighter training program, and additionally, may attend regularly scheduled drills. A Cadet must take and pass appropriate tests as determined by the Fire Chief.
6. If during the firefighter training period, the Fire Chief determines that unsatisfactory progress is being made by a Cadet, the Cadet may be dismissed without recourse. The grievance procedures of these policies and procedures are not available to a Cadet. A dismissal action by the Fire Chief of a Cadet shall not be reviewable by the Board.
7. A Cadet will be issued full personal protective equipment and store it at the Department at all times.
8. A Cadet will not operate power tools at any time unless supervised by a qualified adult member of the Fire Department.
9. A Cadet will maintain a scholastic average of 2.0 or better while attending high school. A Cadet falling below this average will be placed on a "one-time" only probation for a period of one (1) high school quarter. Any subsequent failure to meet the 2.0 average guideline will result in discharge.



GRATON FIRE PROTECTION DISTRICT  
POLICIES AND PROCEDURES

TITLE: CADET (continued)

ADOPTED: 7/11/00

LAST REVISION 8/06/13

---

10. A Cadet between 16 and 17 years of age may not respond to fire, medical, and other types of incidents and may not drive any District vehicle during the course of an incident. Upon successfully completing training, with Fire Chief's permission, and after turning 17 years old, a Cadet may respond to calls following the Cadet Call Response SOG.
11. A Cadet will not enter any burning building ~~or fight fire~~ at any time during any emergency incident.
12. A Cadet shall be accountable to the Fire Chief and will follow the chain of command as outlined in these Policies and Procedures.
13. A Cadet will receive a reimbursement check at the rate outlined in these Policies and Procedures.
14. A Cadet will be given the opportunity to receive Hepatitis B inoculations at no cost to the Cadet with parental approval.
15. A Cadet will be covered by workers compensation insurance and coverage under the District's liability insurance.
16. A Cadet may participate in "Live Fire" training exercises only at age 17-~~1~~<sup>1</sup>/<sub>2</sub> years of age.
17. A Cadet becomes a Firefighter at age 18 after successful completion of the Firefighter training program.

**GRATON FIRE PROTECTION DISTRICT  
BOARD OF DIRECTORS  
BOARD MEETING MINUTES  
3750 Gravenstein Hwy N, Sebastopol, CA 95472  
November 10, 2020 7:00pm**

---

1. Call to Order: 7:00pm
2. Pledge of Allegiance
3. Roll Call: Maddocks, Farmer, Cesaretti, Gray, Nunes; also present: Bullard
4. Corrections to the Agenda: None
5. Scheduled and Unscheduled Appearances: None
6. Old Business
  - a. Update on Insurance – Terrorist Coverage: Should be in place 12/1/20; will be a refund and new check required
  - b. Review Strike Team Response SOG: No update
7. New Business
  - a. CalPERS 457 Retirement Contract: Need to approve a resolution to establish contract. Motion to approve Resolution 20-11-1 by Cesaretti, 2<sup>nd</sup> by Farmer, passed 5/0/0
8. Committee Reports
  - a. Apparatus: 8463 is back but front bumper rebuild was not satisfactory; will go back
9. Approval of prior Board Meeting Minutes
  - a. September 9, 2020: Motion to approve minutes as written by Farmer, 2<sup>nd</sup> by Cesaretti, passed 4/0/1
  - b. September 13, 2020: Motion to approve minutes as written by Farmer, 2<sup>nd</sup> by Gray, passed 3/0/2
  - c. September 30, 2020: Motion to approve minutes as written by Cesaretti, 2<sup>nd</sup> by Nunes, passed 3/0/2
  - d. October 13, 2020: Motion to approve minutes as written by Farmer, 2<sup>nd</sup> by Cesaretti, passed 4/0/1
  - e. October 19, 2020: Not included in Board Packet; table until next meeting
  - f. October 23, 2020: Motion to approve minutes as written by Cesaretti, 2<sup>nd</sup> by Gray, passed 4/0/1
10. Purchase Requests
  - a. Engine bay fans: circulate heat during the winter, cool during the summer. Table for next meeting; share product detail

- b. Exhaust hose drops: add 3 hoses where missing, complete installation. Table for next meeting
- 11. Bills & Warrants
  - a. Motion to approve Check Detail 11-10-20 in the amount of \$122,745.67 by Cesaretti, 2<sup>nd</sup> by Gray, passed 5/0/0
- 12. Budget Report: The budget has been presented and reviewed by the Board
- 13. Correspondence
  - a. Parcel Tax Exemptions: Table for next meeting
- 14. Fire Chief's Report: New Admin Assistant job ad posted
  - a. Roster: Add Lia Liskey and Derek Towne as trainees, Promote Lindsay Cruckshank to Captain, Promote Josh Skikos to Assistant Chief. Motion to add trainees and promote Cruckshank by Farmer, 2<sup>nd</sup> by Cesaretti, passed 5/0/0; table Skikos promotion to next month.
  - b. Alarms: 60 calls during October 2020
  - c. Drills: 8 regular and special trainings and activities during October 2020
- 15. Closed Session: None
- 16. Adjournment: 7:54pm

**GRATON FIRE PROTECTION DISTRICT  
BOARD OF DIRECTORS  
SPECIAL BOARD MEETING MINUTES  
3750 Gravenstein Hwy N, Sebastopol, CA 95472  
November 19, 2020 6:00pm**

---

*Participate by phone (605) 475-4120, passcode 370238#*

---

1. Call to Order: 6:00pm
2. Pledge of Allegiance
3. Roll Call: Maddocks, Farmer, Cesaretti, Gray, Farmer; also present: Bullard, District Counsel
4. Corrections to the Agenda: Motion by Farmer to add emergency meeting as #8 related to COVID declaration by the Governor on new restrictions, 2<sup>nd</sup> by Cesaretti. Voted 5/0/0.
5. Scheduled and Unscheduled Appearances: Alvarez requesting to postpone closed session to have more time to prepare. Board requested to continue tonight as planned and will evaluate if more time/information is necessary.
6. Review Taxpayer Parcel Tax Exemption Requests: Review two letters received.
  - a. 4960 Vine Hill Road – denied request due to two separate parcels
  - b. Vine Hill Vistas Mutual Water Co – request printed language referenced that says there is no fee for parcels exempted by the County.
7. Consideration of Establishment of Ad Hoc Committee for Fire Chief Job Description and Stipend: Farmer and Cesaretti to form ad hoc committee to establish part time paid fire chief position. Expect to bring forward at December 8<sup>th</sup> meeting.

----- Special Meeting Paused: 6:35pm -----

Pursuant to Govt Code section 54956.5(b) public health emergency developments in changes to COVID protocols,

Motion by Farmer to convene emergency meeting, 2<sup>nd</sup> by Nunes, 5/0/0

----- Emergency Meeting Call to Order: 6:35pm -----
8. COVID Discussion: Masks during business hours while at the station to further reduce risk of spread. Okay to continue training while following precautions (e.g., hand sanitizer, masks, social distancing).

----- Motion by Farmer to adjourn emergency meeting, 2<sup>nd</sup> by Nunes, 5/0/0. 6:44pm -----

----- Special Meeting Reconvenes: 6:44pm -----
9. Public Comment on Closed Session: None
10. Closed Session: Public Employee Discipline/Dismissal/Release (Govt Code section 54957(b)
  - a. Entered: 6:51pm
  - b. Exited: 7:54pm

**ADA Compliance**

*In compliance with Government Code 54954.2(a), the Graton Fire Department, will, on request, make this agenda available in appropriate alternative formats to persons with a disability, as required by the section 202 of the American Disabilities Acts of 1990 (42 U.S.C. 12132), and the federal rules and regulations adopted in implementation thereof. Individuals who need this agenda in an alternative format or who need a disability-related modification or accommodation in order to participate in the meeting should contact Board Recording Secretary, at (707) 823-8400 x107, 72 hours or more prior to the disability accommodations being needed in order to participate in the meeting.*

11. Report out of Closed Session: By a vote of 4/0/1 (Director Nunes abstaining), the Board decided to reinstate the firefighter.
12. Adjournment: 7:55pm

**ADA Compliance**

*In compliance with Government Code 54954.2(a), the Graton Fire Department, will, on request, make this agenda available in appropriate alternative formats to persons with a disability, as required by the section 202 of the American Disabilities Acts of 1990 (42 U.S.C. 12132), and the federal rules and regulations adopted in implementation thereof. Individuals who need this agenda in an alternative format or who need a disability-related modification or accommodation in order to participate in the meeting should contact Board Recording Secretary, at (707) 823-8400 x107, 72 hours or more prior to the disability accommodations being needed in order to participate in the meeting.*



**Apparatus Bay Ceiling & Redistribution Fans**  
**12/8/2020**

**Description:** Add fans to apparatus bays to 1) move heat from ceiling back to floor and 2) cool during the summer

	Vendor Materials	Price	Installation	Total
1	Norman Wright Mechanical	<del>\$ 11,153</del> \$ 8,922	\$ 3,500	\$ 12,422
2	Zoro Tools	\$ 12,086	\$ 3,500	\$ 15,586
3	Global Industrial	\$ 12,137	\$ 3,500	\$ 15,637

**Motion Requested:** Motion to purchase fans from Norman Wright Mechanical and have Raynor Electric install, not to exceed \$13,000



# NORMAN S. WRIGHT

Mechanical Equipment Corporation

99A South Hill Drive, Brisbane, CA 94005-1282 • tel 415.467.7600 • fax 415.467.0900

Heating  
Ventilation  
Air Conditioning  
Hydronic Systems

norman-wright.com

## QUOTATION

TO: Graton Fire Protection District  
ATTN: Bill Bullard

DATE: 11/13/2020  
PAGE: 1 of 3

TERMS: TBD      FOB: Factory      SHIP TIME: See below      QUOTE #: NSWJOB197

**This Quotation Subject To Acceptance Within 30 Days And Subject to Manufacturer's Escalation Cost at the time of the order.**  
To the prices and terms quoted, add any manufacturers' gross receipts, sales or use tax, either Federal, State or City, payable on the transaction under any affecting statute. Orders will be invoiced at price in effect at time of shipping, unless otherwise specified. All orders subject to factory acceptance. No material will be accepted for return without permission. Orders may not be canceled without written permission from the manufacturers. Cancellation charges may apply. No warranty is offered or implied, other than the standard warranty of the manufacturer. Written copies available on request. Unless otherwise stated, we do not include: seismic calculations, disconnect switches, starters, controls, thermostats, damper motors, internal wiring, drives, belt guards, filters, gauges, vibration isolators, and start-up service or supervision. Programming of DDC controls is not included in this quotation. **Subject to attached terms and conditions.**

**PROJECT:** Graton Fire Protection District - Big Ass Fans

**QTY: 1**

**Product:** HVLS Fan – Big Ass Fans – 12ft Essence  
**Power:** 110–125V, 1Φ, 60Hz, 10A  
**Mounting:** Universal Mount  
**Extension:** 7ft  
**Optional Equipment Included:** Z-Purlin Mounting Kit  
**Tag:** Apparatus East

**INCLUDED AS STANDARD:**

- Airfoils and Winglets — Eight anodized Mini-Ellipto airfoils with winglets (black or silver).
- Gearless Direct Drive Motor — White or silver; permanent magnet design reduces power consumption.
- Extension Tube — Standard 2 ft (0.6 m); optional 3 to 15 ft (0.9 to 4.6 m).
- Controller — Wired wall controller mounts in standard single-gang junction box or to wall surface; connects with 10V CAT5 cable.
- Environment — Suitable for indoor and outdoor spaces.
- Colors — Standard color options for Essence are silver and black.
- Warranty — Mechanical: 10 years — Electrical: 5 years.

**Exclusion:** LED Light Kit / Mounting / Conduit Runs / Permits / SmartSense / Wiring / Additional Extension Tubes / Stabilizer Kit / Special Finishes / Custom Color / Outdoor Application / Stainless Steel Options / Hardware / Training / Labor Warranty / Afterhours or Weekend Labor / Fire Relay Termination at Panel / Air Freight Shipping of Parts / Jobsite Visit / Extended Warranty / 2% Surcharge for Credit Card Orders

**QTY: 1**

**Product:** HVLS Fan – Big Ass Fans – 10ft Essence  
**Power:** 110–125V, 1Φ, 60Hz, 10A  
**Mounting:** Universal Mount  
**Extension:** 7ft  
**Optional Equipment Included:** Z-Purlin Mounting Kit  
**Tag:** Apparatus West

**INCLUDED AS STANDARD:**

- Airfoils and Winglets — Eight anodized Mini-Ellipto airfoils with winglets (black or silver).
- Gearless Direct Drive Motor — White or silver; permanent magnet design reduces power consumption.
- Extension Tube — Standard 2 ft (0.6 m); optional 3 to 15 ft (0.9 to 4.6 m).

**PROJECT:** Graton Fire Protection District - Big Ass Fans

- Controller — Wired wall controller mounts in standard single-gang junction box or to wall surface; connects with 10V CAT5 cable.
- Environment — Suitable for indoor and outdoor spaces.
- Colors — Standard color options for Essence are silver and black.
- Warranty — Mechanical: 10 years — Electrical: 5 years.

**Exclusion:** LED Light Kit / Installation / Mounting / Conduit Runs / Permits / SmartSense / Wiring / Additional Extension Tubes / Stabilizer Kit / Special Finishes / Custom Color / Outdoor Application / Stainless Steel Options / Hardware / Training / Labor Warranty / Afterhours or Weekend Labor / Fire Relay Termination at Panel / Air Freight Shipping of Parts / Jobsite Visit / Extended Warranty / 2% Surcharge for Credit Card Orders

**QTY: 2**

**Product:** Airius – AirPear – A-25-EC-STD-100-130-W

**Power:** 100-130VAC, 60Hz, 0.46A, 31.3W

**Optional Equipment Included:** EC-MOD (Qty. 2), POT-1 (Qty. 1)

**Tag:** Mezzanine

**INCLUDED AS STANDARD:**

- Housing: PC/ABS, 5VA flame resistance. OffWhite.
- Controls: EC- MOD is a control module that opens the control capability of the fan. POT-1 is a potentiometer, wall mounted speed control.
- Motor: Electrically commutated, thermally protected axial motor by ebm-papst®, 92% efficient.
- Temperature: -22°F (-30°C) to 122°F (50°C).
- Stator: Patented multi-vane stator significantly increases air throw for maximizing performance.
- Certification: Conforms to UL-507, CAN/CSA-C22.2 No. 1113, UL 94 5VA and is ETL listed in USA and Canada.
- Safety Cable: 6' length steel cable (fastened to body).
- Warranty: 3 years parts and workmanship.

**Exclusion:** Hanging Method / Installation / Designer Series / Suspended Series / Stabilizer Kit / Special Finishes / Custom Color / Outdoor Application / Short Nozzle / Additional Hardware / Air Freight Shipping of Parts / Jobsite Visit / Extended Warranty / 2% Surcharge for Credit Card Orders

**Total Bid Cost, Freight Included \$10,279.00 + TAX**

**Promotional Cost (Valid until 12/14/20), Freight Included \$8,242.00 + TAX**

Norman S. Wright Equipment Corporation

Jose L Bocanegra

TECHNICAL SPECIFICATIONS

# ESSENCE

THE BEST FAN FOR A BIG SPACE, INDOORS OR OUT

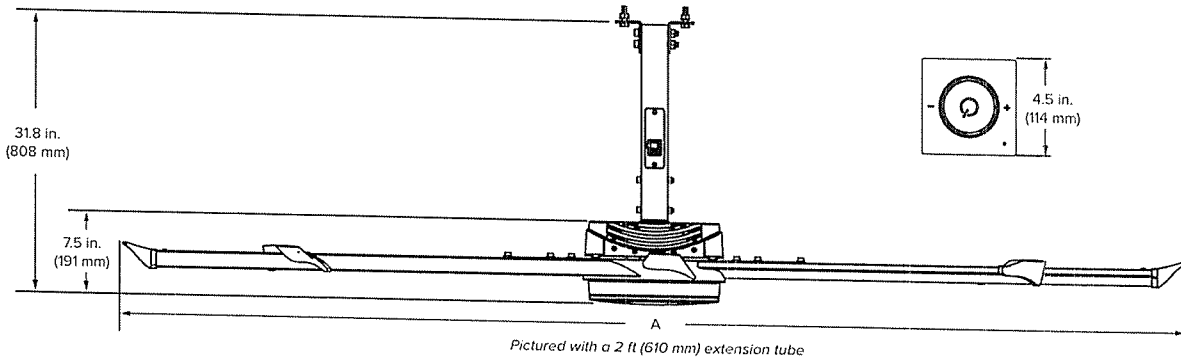
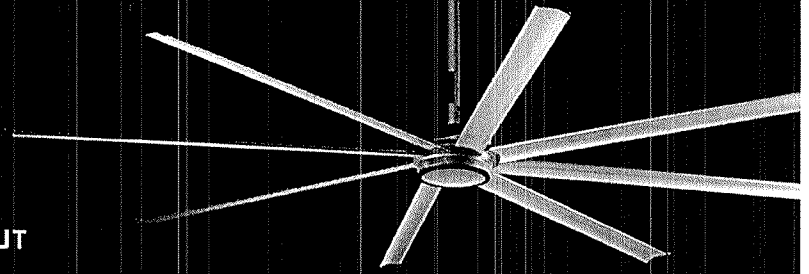

## Technical Specifications

Diameter (A)	Weight <sup>1</sup>	Max Speed	Input Power and Required Breaker	Airfoil Clearances <sup>2</sup>	Sound at Max Speed <sup>3</sup>	IP Rating	Max Operating Temperature	Environment <sup>4</sup>
8 ft (2.4 m)	75 lb (34 kg)	158 RPM	110–125 VAC, 1 $\Phi$ , 50/60 Hz, 10 A 200–240 VAC, 1 $\Phi$ , 50/60 Hz, 10 A	2 ft (0.6 m) on sides 2 ft (0.6 m) below ceiling deck	< 35 dBA	IP43	-4°F to 131°F (-20°C to 55°C)	Suitable for indoor or outdoor spaces
10 ft (3 m)	81 lb (37 kg)	107 RPM						
12 ft (3.7 m)	88 lb (40 kg)	76 RPM						
14 ft (4.3 m)	96 lb (44 kg)	56 RPM						

## Construction Features

Airfoils	Motor and Drive	Certifications <sup>5</sup>	Mounting	Accessories	Colors
Eight anodized Mini-Ellipto airfoils with winglets (black or silver)	Gearless direct drive motor		Standard upper mount installs to bar joists Optional kits allow for mounting to I-beams, solid beams, and purlins	LED Light Wireless Wall Controller	Standard colors are silver and black. Individualize your fan with one of our classic color upgrades, or work with our design consultants to create a shade that's all your own.

### Standard Color Options

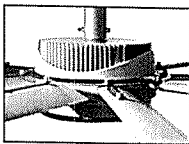

White Motor Housing with Silver Trim

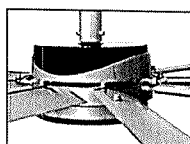

Silver Motor Housing with Black Trim

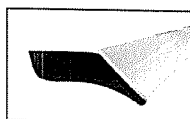
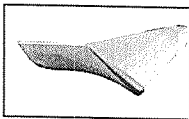

### LED Light

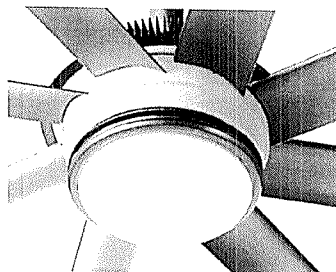

See the Essence LED spec sheet for details.

### Control Options

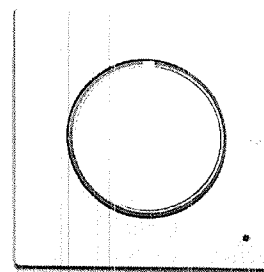

Wired Wall Controller

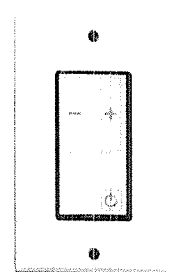

Wireless Wall Controller (Optional)

<sup>1</sup>Weight does not include mount or extension tube.

<sup>2</sup>Suitable for ceilings as low as 12 ft (3.7 meters). Measure the distance from the tip of the winglet to the ceiling or major obstruction.

<sup>3</sup>Fans are sound tested at a maximum speed in a laboratory environment. Actual results in field conditions may vary due to sound reflecting surfaces and environmental conditions.

<sup>4</sup>Not suitable for salt air environments.

<sup>5</sup>Certifications listed here apply to the fan and do not include accessories.

Lead times may vary. See full warranty for coverage information.



USA  
BIGASSFANS.COM  
877-244-3267

CANADA  
BIGASSFANS.COM  
844-924-4277

AUSTRALIA  
BIGASSFANS.COM/AU  
1300 244 277

SINGAPORE  
BIGASSFANS.COM/SG  
65 6709 8500

MALAYSIA  
BIGASSFANS.COM/SG  
603 5565 0888

# TECHNICAL SPECIFICATIONS

MAX COVERAGE: UP TO 25 FT CEILING, 1200 FT<sup>2</sup>

# AIR PEAR 25-EC

AIRIUSFANS.COM | 888-247-7327

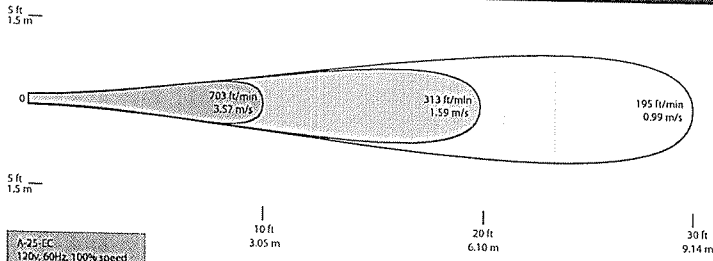

**Housing:** PC/ABS, UL 94 5VA flame resistance.

**Motor:** 230mm, electrically commutated, thermally-protected axial motor by ebm-papst®. Operating temperature: -22°F (-30°C) to 122°F (50°C). No lubrication required, bearings are sealed.

**Power Cord:** 6 foot cord and plug provided for 100-130V fans, no plug for 200-250V.

**Control Input:** 0-10VDC.

**Stator:** Patented multi-vane stator significantly increases air throw for maximizing performance.

**Certification:** Conforms to UL-507, CAN/CSA-C22.2 No. 1113. ETL listed in USA and Canada.

**Safety Cable:** 6' length steel cable (fastened to body)

**Warranty:** 3 years parts and workmanship.

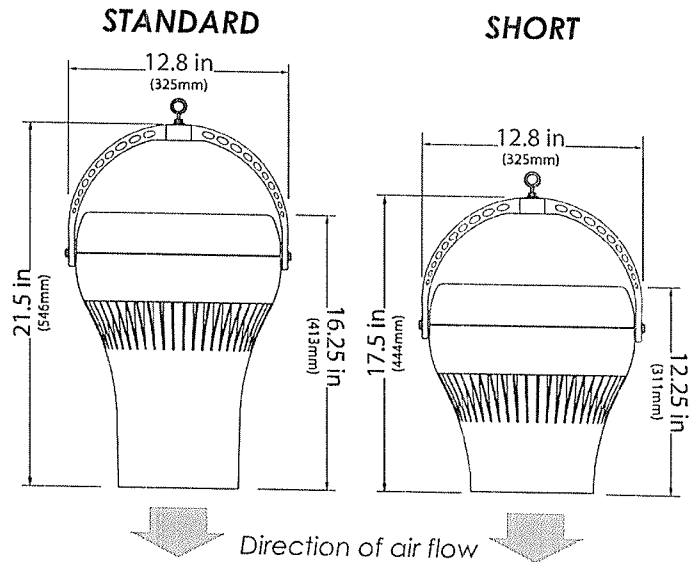

## Technical Specifications



Model	Input Power, 1 Ø	Amps	Watts	RPM	dB(A) <sup>1</sup>	Weight	Colors
A-25-EC-STD-100-130-X	100-130VAC, 60Hz	0.46	31	1640	44, 42, 40	9 lbs.	X = Off white (W), gray (G) or black (B)
A-25-EC-STD-200-250-X	200-250VAC, 60Hz	0.26	30	1700	44, 42, 40	9 lbs.	X = Off white (W), gray (G) or black (B)
A-25-EC-SH-100-130-X	100-130VAC, 60Hz	0.46	31	1640	44, 42, 40	7 lbs.	X = Off white (W), gray (G) or black (B)
A-25-EC-SH-200-250-X	200-250VAC, 60Hz	0.26	30	1700	44, 42, 40	7 lbs.	X = Off white (W), gray (G) or black (B)

<sup>(1)</sup> Calculated sound pressure at 15, 20 and 25 foot distances based on non-reflective area. 69 dB(A) Sound Power Level, designed to meet ISO 3744 - engineering grade precision for determining sound power. Data independently verified by third party. Tests performed in-unit.

## Controls & Factory Installed Options

Item	Description
Pearlink-F	Pearlink Fan Sensor- One Per Fan. Wi-Fi iOS/Android App based controller
Pearlink-T	Pearlink wired (120v) Floor Thermostat- One Per Room
POT-1	Wall-mounted speed control. Low voltage control wiring daisy-chained between fans to be controlled as a group.
BACnet	BACnet/IP package for integration with an existing BACnet system. Individually control speed, on/off and monitor fan status.
GUARD25	Intake grille: Phosphated steel coated in black plastic. Recommended for installations where occupants can reach fans.
BABS	Black ABS housing upgrade for increased chemical resistance. Applications such as machine shops or pools.

<b>Model:</b>	<b>Qty:</b>
Controls/Options:	Qty:

Date: 10/30/2020	Customer: Graton Fire Protection District   Contact: Chief Bill Bullard Phone: 707-823-8400   Email: bbullard@grantonfire.com
Proposal #: 10/30/2020G	Address: 3750 Gravenstein Hwy North, Sebastopol CA 95472   Job Location: Same

> **Scope of Work:** Weidner Fire will provide parts for the MagneGrip 100% source capture exhaust removal system. This proposal includes equipment only.

> **Project Overview:** Three MagneGrip hose assemblies for sliding balancer track systems for back-in apparatus parking configuration. Sliding balancer track hose to be added to existing tracks.

QTY	P/N	DESCRIPTION	PRICE EA.	EXT. PRICE
3	500094-21	MagneGrip 4" x 21' blue and white hose, heat resistant to 400 degrees.	342.60	1,027.80
3	530407-02	MagneGrip 4" lifting elbow with rubber bands and hose clamps	100.00	300.00
3	500002-74	MagneGrip internal lifting cable with hook and gripple. .	14.25	42.75
3	500084-16	MagneGrip externa balancer cable with two carabiners.	10.50	31.50
3	530621-01	MagneGrip 4" knob handle and hose assembly. 4" knob handle, 4" x 24" lower hose, pressure sensor, standard transmitter, rubber bands and hose clamps.	462.86	1,388.58
3	500076-01	MagneGrip 4" nozzle assembly with rubber boots and magnets, rubber bands and hose clamps.	450.00	1,350.00
3	500001-01	MagneGrip sliding balancer track trolley.	130.00	390.00
3	500084-04	MagneGrip blue balancer.	582.00	1,746.00
1	540555-01	MagneGrip wireless receiver for existing control panel.	150.75	150.75
6	500003-65	MagneGrip 4" EPDM rubber bands.	3.00	18.00
6	510400-02	MagneGrip stainless steel 4" hose clamps.	4.50	27.00
1	Freight	Estimated shipping for delivery to zip code 95472.	600.00	600.00
			<b>TOTAL:</b>	<b>7,072.38</b>

*Delivery of equipment will be within 3 weeks of proposal acceptance. Quotation is valid for 90 day.*

**Payment Terms:** Equipment portion of project due at time of order, balance due upon completion of installation and training.

All material is guaranteed to be as specified. All work to be completed in a professional manner according to standard practices. Any alteration or deviation from above specifications involving extra costs will be executed only upon written orders and will become an extra charge over and above the quotation. All agreements contingent upon acts of God, such as severe acts of nature or weather events including floods, fires, earthquakes, hurricanes, explosions, war, acts of terrorism, epidemics, pandemics, strikes and labor disputes, or other delays beyond our control. Owner to carry fire, tornado, and other necessary insurance. Weidner Fire is licensed and insured according to all laws and regulations.



267 East Airway Blvd  
Livermore, CA 94551  
Phone: 925-449-7210  
Fax: 925-449-7201

To:  
Chief Bill Bullard  
Graton Fire Department  
Phone: 707-823-8400 x 101  
Email: chief@gratonfire.com

Date:12/7/2020

**Quotation Valid for 60 Days.**

<u>ITEM</u>	<u>QTY</u>	<u>DESCRIPTION</u>	<u>PRICE</u>	<u>AMOUNT</u>
1	21	MSA G1 45 Minute Cylinder Assy. P/N 807570-SP	\$825.00	\$17,325.00
2	2	MSA G1 60 Minute Cylinder Assy. P/N 10127946-SP	<u>\$1,005.00</u>	<u>\$2,010.00</u>
		Sub Total		\$19,335.00
		Sales Tax 8.25%		\$1,595.14
		Shipping & Handling		<u>N/C</u>
		Total		\$20,930.14

Prices do not include shipping/handling charges or sales tax unless specified. **Quotation prices are valid for 60 days.** Call 925-449-7210 if past expiration date.

Thank you for the opportunity to submit this quotation. If you have any questions please give us a call.

Sincerely,

Tim McGuire  
Branch Manager  
925-449-7210  
tim.mcguire@bauersf.com

<b>Num</b>	<b>Name</b>	<b>Memo</b>	<b>Graton</b>	<b>Tree Farm</b>
3659	Amanda Roy	July-Nov Call/Drill Reimb.	\$ 49.00	
3660	Bill Bullard	July-Nov Call/Drill Reimb.	\$ 3,865.00	
3661	Bob Maddocks	Board Reimbursement	\$ 150.00	
3662	Burtons Fire Inc.	8482 Parts, Valve; 8460 Parts - gauges, lights	\$ 1,210.82	
3663	Cal Net ATT	Telephone	\$ 206.27	
3664	CalChoice	Health Benefits - Jan 2021	\$ 4,143.56	
3665	Capital One Public Funding	Mortgage Payment	\$ 33,935.52	
3666	Capitol Clutch & Brake Inc	Drain Cock	\$ 144.71	
3667	Cascade Fire Equipment Co.	Small Tools	\$ 711.77	
3668	Chaz Mathias	July-Nov Call/Drill Reimb.	\$ 66.00	
3669	Choice Builder	Dental/Vision - Dec 2020	\$ 519.44	
3670	Cliff Walker Supply & Maint	Station Cleaning x4	\$ 600.00	
3671	Darrell Kopriva	July-Nov Call/Drill Reimb.	\$ 447.00	
3672	DK Embroidery & Monogramming	Tree Hats x6	\$ 81.19	
3673	Dustin Blumenthal	July-Nov Call/Drill Reimb.	\$ 462.00	
3674	Evan Jacobs	July-Nov Call/Drill Reimb.	\$ 65.00	
3675	Friedmans Home Improvement	Pond pots, Trees x30, Fasteners, Poly Sheeting	\$ 1,442.61	
3676	Frog Power Equipment LLC	Chainsaw Chain	\$ 21.80	
3677	Graton Firefighters' Association	Board Reimbursement (Gray)	\$ 175.00	
3678	Heather O'Dell	Employee Shirts; Box Cutters; Hand Sanitizers	\$ 89.44	
3679	Ian Muskar	Reimbursement for fuel and Engineer Meeting	\$ 727.19	
3680	Jacob Mual	Board Reimbursement	\$ 287.00	
3681	Janin Comiskey	Bookkeeping Services	\$ 900.00	
3682	Jason Nunes	Board Reimbursement	\$ 275.00	
3683	Jenna Dunbar	July-Nov Call/Drill Reimb.	\$ 308.00	
3684	Jonathan Preciado	July-Nov Call/Drill Reimb.	\$ 64.00	
3685	Josh Skikos	July-Nov Call/Drill Reimb.	\$ 282.00	
3686	Kyle Bartlett	July-Nov Call/Drill Reimb.	\$ 323.00	



Graton Fire Protection District  
 Check Detail 12/8/2020

<b>Num</b>	<b>Name</b>	<b>Memo</b>	<b>Graton</b>	<b>Tree Farm</b>
3687	Kyler L. Walker	July-Nov Call/Drill Reimb.	\$ 14.00	
3688	Levi DeCarly	July-Nov Call/Drill Reimb.	\$ 14.00	
3689	Liebert Cassidy Whitmore	HR Legal Advice	\$ 1,670.00	
3690	Linda Lucia	Tree Farm Reimbursement	\$	108.68
3691	Lindsay Cruckshank	July-Nov Call/Drill Reimb.	\$ 292.00	
3692	Mario Cesaretti	Board Reimbursement	\$ 250.00	
3693	Matt Miller	July-Nov Call/Drill Reimb.	\$ 84.00	
3694	Matt Skinner	July-Nov Call/Drill Reimb.	\$ 432.96	
3695	Merrill, Arnone & Jones, LLP	Personnel Matters	\$ 2,100.00	
3696	Napa Auto Parts	Battery, Oil/filters; Belt; Toggle	\$ 617.25	
3697	North Bay Tree Weed & Pest	Weed Control	\$ 670.00	
3698	Occu-Med	Drug Testing x2	\$ 134.10	
3699	One Call	Maintenance on 8400, 8482, 8485, 8481, 8441	\$ 3,566.15	
3700	PG&E	Utilities	\$ 103.30	
3701	PRMD	Annual Water Monitoring	\$ 224.00	
3702	Robert Sabrowsky	Reimbursement	\$ 776.00	
3703	Royal Logistics & Transportation	Christmas Trees - Shipping	\$ 1,700.00	
3704	Ryan Fernandez	July-Nov Call/Drill Reimb.	\$ 155.00	
3705	Sam Ballenger	July-Nov Call/Drill Reimb.	\$ 631.00	
3706	Sapphire Alvarez	July-Nov Call/Drill Reimb.	\$ 429.00	
3707	Scott Fisher	July-Nov Call/Drill Reimb.	\$ 488.00	
3708	Sebastopol Hardware Center	Shelving for FD, Tree Farm Expenses	\$ 54.85	118.88
3709	Shane Spelman	July-Nov Call/Drill Reimb.	\$ 56.00	
3710	Standard Insurance Company	Disability Insurance	\$ 165.00	
3711	The Classic Duck	Ornaments x72	\$	516.60
3712	The Fire Store	Fire Helmet	\$ 309.16	
3713	Torrey Farmer	Board Reimbursement	\$ 175.00	
3714	Zach Colenzo	July-Nov Call/Drill Reimb.	\$ 231.00	
3715	Zoro Tools	Trash/Water Pump	\$ 602.39	
50643	Zachary Aldridge	P/R Tree Farm	\$	413.26
DD	Jackson Barnard	P/R Tree Farm	\$	820.88

Graton Fire Protection District  
 Check Detail 12/8/2020

<i>Num</i>	<i>Name</i>	<i>Memo</i>	<i>Graton</i>	<i>Tree Farm</i>
50644	Stephen Bullard	P/R Tree Farm		\$ 242.41
DD	Jackson Comiskey	P/R Tree Farm		\$ 520.03
50645	Forrest Edson	P/R Tree Farm		\$ 499.52
DD	Austin Kolsom	P/R Tree Farm		\$ 639.19
50646	Linda Lucia	P/R Tree Farm		\$ 1,832.34
DD	Michael Martinez	P/R Tree Farm		\$ 804.38
DD	Adam McMannus	P/R Tree Farm		\$ 373.04
50647	Justeen Moritz-Wood	P/R Tree Farm		\$ 456.63
50648	Heather O'Dell	P/R Tree Farm		\$ 2,549.25
DD	Ryan Reyes	P/R Tree Farm		\$ 213.73
50649	Anthony Tweedie	P/R Tree Farm		\$ 282.82
50650	Darrell Kopriva	P/R Stipend	\$ 554.10	
DD	Samuel Ballenger	P/R Stipend	\$ 554.10	
DD	Jenna Dunbar	P/R Stipend	\$ 525.77	
DD	Jacob Mual	P/R Stipend	\$ 138.52	
DD	Dustin Blumenthal	P/R Career	\$ 4,978.25	
DD	Dustin Parker	P/R Career	\$ 4,871.46	
DD	Kyler L. Walker	P/R Career	\$ 4,473.33	
DD	Kyle Bartlett	P/R Career	\$ 3,890.43	
DD	Matt Miller	P/R Career	\$ 3,821.39	
DD	Shane Spelman	P/R Career	\$ 4,208.48	
	ADP	P/R Taxes 11-10-20	\$ 6,376.63	\$ 2,376.80
	ADP	P/R Processing Fees	\$ 104.16	
			\$ 100,439.25	\$ 14,322.29
		<b>TOTAL</b>	<b>\$114,761.54</b>	

**Graton Fire Protection District  
US Bank Report Report  
December 8, 2020**

Name	Memo	Split	Amount
Ace Hardware	Hose Testing Tape	6140 · Equipment Maintenance	28.73
Shell Oil	Fuel	7201 · Gas/Oil	53.27
GCR Tires & Service	Tire Repair	6155 · Vehicle Maintenance	93.30
Public Safety LMR	Lapel mics x6	6040 · Communications	498.00
Ebay	Chain Saw Parts	6140 · Equipment Maintenance	12.50
Amazon	Bed Lights	6155 · Vehicle Maintenance	40.04
Raley's	Station Upstaffing	7120 · In-Service Training	16.60
Smart Food Service	Station Upstaffing	7120 · In-Service Training	26.69
Costco	Station Upstaffing	7120 · In-Service Training	182.84
Pay Pal	LED-8400 Grill Lights	6155 · Vehicle Maintenance	122.91
Webology	Website Hosting	6400 · Office Expense	139.86
Craigslist	Admin Job Ad	6400 · Office Expense	75.00
North American Rescue	Touring x35	6880 · Small Tools/Instruments	794.80
Indeed	Admin Job Ad	6400 · Office Expense	26.05
Nanochem Tech	Station Window Paint	6180 · Building Maintenance	306.30
Costco	Paper Supplies	6080 · Household Expense	120.37
Costco	Paper Supplies	6080 · Household Expense	9.80
Indeed	Admin Job Ad	6400 · Office Expense	19.71
Verizon Wireless	Cellular	6040 · Communications	130.64
Amazon	Pens; Umbrella	6880 · Small Tools/Instruments	47.55
Quill	Hand Soap	6080 · Household Expense	18.58
Papa Murphys	Office Meeting	7120 · In-Service Training	19.00
AT&T	Internet	7320 · Utilities	64.20
Amazon	Small Engine Fuel	7201 · Gas/Oil	104.43
Amazon	Chevron Tape	6140 · Equipment Maintenance	25.96
Ebay	Copier Ink	6400 · Office Expense	42.05
Ebay	Copier Ink	6400 · Office Expense	84.43
Ebay	Copier Ink	6400 · Office Expense	54.47
Supply Cache.com	Case	6880 · Small Tools/Instruments	279.36
Amanda Roy	Chevron Tape	6140 · Equipment Maintenance	9.73
Pay Pal	Radio Holsters	7000 · Tree Farm Expense	36.31
USPS	Postage	6400 · Office Expense	2.00
Amazon	Clipboards	6880 · Small Tools/Instruments	87.24
Optics Planet, Inc	Binoculars	6880 · Small Tools/Instruments	141.69
Amazon	Clipboards	6880 · Small Tools/Instruments	75.43
Smart Food Service	Gloves	7000 · Tree Farm Expense	14.50
Amazon	File Folders	6400 · Office Expense	22.28
Costco	Cider Supplies	7000 · Tree Farm Expense	119.94
Pacific Sanitation	Portable Toilet	7000 · Tree Farm Expense	457.26
Sonoma Media for Press De	Press Democrat Ad	7000 · Tree Farm Expense	200.00
USPS	Postcard Stamps	7000 · Tree Farm Expense	131.25
Kelly Moore	Sign Paint	7000 · Tree Farm Expense	63.92
			<b>4,798.99</b>

DEPOSITS	
Transfer from ICS	60,000.00
Tree Farm Income	35,780.04
L.Tripoli	752.00
Auto Ins Refund	227.00
Mort refund for Refi	2,388.17
Total:	99,147.21

CURRENT ASSETS	
Summit State Operating Account:	8,945.78
Summit State ICS Account:	1,312,360.18
Total:	1,321,305.96

ACCOUNTS RECEIVABLES	Amount	Payment	Date
FEMA- Kincade Fire	151,829.58		10/13/2020
State of CA- LNU Strike Team	227,458.45		12/8/2020
FEMA- LNU Station Staffing	180,443.07		12/8/2020
State of CA - Glass Fire Strike Team	216,943.32		12/8/2020
	776,674.42		

**Graton Fire Protection District**  
**Profit & Loss Budget vs. Actual**  
 July 1 through December 8, 2020

Ordinary Income/Expense	<u>Jul 1 - Dec 8, 20</u>	<u>Budget</u>	<u>% of Budget</u>
<b>Income</b>			
<b>10 · Taxes</b>			
1000 · Property Taxes - CY Secured	0.00	916,187.00	0.0%
1001 · Parcel Taxes - CY	0.00	877,365.00	0.0%
1004 · Property Taxes -CY Secured July	0.00	0.00	0.0%
1011 · Property Taxes - Admin Fee	0.00	-9,000.00	0.0%
1012 · CY Property Tax Homeowners Relf	0.00	0.00	0.0%
1014 · CY Property Taxes Backfill	0.00	0.00	0.0%
1020 · Property Taxes -CY Supplemental	0.00	17,000.00	0.0%
1040 · Property Taxes -CY Unsecured	0.00	22,000.00	0.0%
1042 · Cost Reim-Coll Del CY Unsec	0.00	-500.00	0.0%
1044 · Property Taxes -CY Unsec (July)	0.00	0.00	0.0%
1060 · Property Taxes -PY Secured	0.00	-500.00	0.0%
1080 · Property Taxes -PY Supplemental	0.00	0.00	0.0%
1100 · Property Taxes -PY Unsecured	0.00	500.00	0.0%
1120 · - State- Other in Lieu	0.00	0.00	0.0%
10 · Taxes - Other	0.00	0.00	0.0%
<b>Total 10 · Taxes</b>	<u>0.00</u>	<u>1,823,052.00</u>	<u>0.0%</u>
<b>17 · Use of Money/Property</b>			
1700 · Interest on Pooled Cash	0.00	500.00	0.0%
1701 · Interest Earned	0.00	500.00	0.0%
1750 · Interest from Bank	0.00	0.00	0.0%
17 · Use of Money/Property - Other	0.00	0.00	0.0%
<b>Total 17 · Use of Money/Property</b>	<u>0.00</u>	<u>1,000.00</u>	<u>0.0%</u>
<b>20 · Intergovernmental Revenues</b>			
2400 · ST - Disaster Relief	0.00	0.00	0.0%
2440 · ST - HOPTR	0.00	5,000.00	0.0%
2500 · ST - Grants/Other	0.00	20,000.00	0.0%
2589 · State Revenue - Strike Team	0.00	360,000.00	0.0%
20 · Intergovernmental Revenues - Other	0.00	0.00	0.0%
<b>Total 20 · Intergovernmental Revenues</b>	<u>0.00</u>	<u>385,000.00</u>	<u>0.0%</u>
<b>40 · Miscellaneous Revenues</b>			
4020 · Tree Farm Revenue	14,813.12	70,000.00	21.16%
4021 · Sale - Real Property	37,061.00	0.00	100.0%
4040 · Miscellaneous Revenue	5,386.69	4,078.00	132.09%
4101 · Ins/Personal Damage Rebate	0.00	0.00	0.0%
4102 · Donations/Reimbursements	0.00	2,000.00	0.0%
4109 · Outdated/Cancelled Checks	0.00	0.00	0.0%
4600 · Sale of Fixed Asset	0.00	0.00	0.0%
4620 · Unclaimed-OT-Within Fund	0.00	0.00	0.0%

**Graton Fire Protection District**  
**Profit & Loss Budget vs. Actual**  
July 1 through December 8, 2020

	<u>Jul 1 - Dec 8, 20</u>	<u>Budget</u>	<u>% of Budget</u>
40 · Miscellaneous Revenues - Other	2,624.25	0.00	100.0%
<b>Total 40 · Miscellaneous Revenues</b>	<b>59,885.06</b>	<b>76,078.00</b>	<b>78.72%</b>
<b>Total Income</b>	<b>59,885.06</b>	<b>2,285,130.00</b>	<b>2.62%</b>
<b>Expense</b>			
50 · Salaries/Employee Benefits			
5910 · Payroll Expenses	78,708.09	540,000.00	14.58%
5911 · Reimbursement- Calls/Drills	12,825.00	50,000.00	25.65%
5912 · Pay- Strike Team	326,807.35	240,000.00	136.17%
5913 · Reimbursement- Boards/Comms	1,025.00	3,000.00	34.17%
5914 · Pay- Administrative Payroll	9,605.66	32,400.00	29.65%
5915 · Stipend Pay	28,380.37	120,450.00	23.56%
5916 · Overtime	0.00	86,400.00	0.0%
5917 · Sleeper Reimbursement	0.00	29,200.00	0.0%
5918 · Contract Employees	32,277.08	3,000.00	1,075.9%
5923 · Retirement- CalPERS	0.00	75,600.00	0.0%
5924 · Retirement- 457 Plan	0.00	4,000.00	0.0%
5925 · FICA (Medicare/SS)	0.00	16,495.00	0.0%
5930 · Health Insurance	18,132.56	90,000.00	20.15%
5931 · Disability Insurance	0.00	1,980.00	0.0%
5935 · Unemployment	0.00	15,931.00	0.0%
5940 · Workers Comp	5,410.00	82,277.00	6.58%
50 · Salaries/Employee Benefits - Other	660.00	0.00	100.0%
<b>Total 50 · Salaries/Employee Benefits</b>	<b>513,831.11</b>	<b>1,390,733.00</b>	<b>36.95%</b>
60 · Supplies and Services			
6020 · Clothing/Personal	18,361.96	40,000.00	45.91%
6040 · Communications	4,718.32	46,000.00	10.26%
6080 · Household Expense	1,707.01	4,000.00	42.68%
6100 · Liability Insurance	36,722.67	40,000.00	91.81%
6140 · Equipment Maintenance	2,540.88	15,000.00	16.94%
6155 · Vehicle Maintenance	16,323.91	55,000.00	29.68%
6180 · Building Maintenance	11,750.95	34,000.00	34.56%
6190 · Landscape Services	1,450.27	12,000.00	12.09%
6235 · Local Project Maintenance	0.00	0.00	0.0%
62400 · Depreciation Expense	0.00	0.00	0.0%
6261 · Medical Supplies	17,683.98	17,000.00	104.02%
6280 · Memberships	0.00	3,000.00	0.0%
6400 · Office Expense	12,955.34	8,000.00	161.94%
6461 · Operational Expense	0.00	0.00	0.0%
6521 · County Services	0.00	0.00	0.0%
6526 · Dispatch Services	0.00	0.00	0.0%
6536 · Bank Fees	0.00	0.00	0.0%

**Graton Fire Protection District**  
**Profit & Loss Budget vs. Actual**  
July 1 through December 8, 2020

	<u>Jul 1 - Dec 8, 20</u>	<u>Budget</u>	<u>% of Budget</u>
6587 · LAFCO	1,718.00	1,741.00	98.68%
6598 · Environment	0.00	0.00	0.0%
6610 · Legal Services	12,780.00	15,000.00	85.2%
6630 · Audit Services	5,900.00	11,000.00	53.64%
6800 · Public/Legal Notices	29.67	500.00	5.93%
6820 · Rent/Lease Equipment	0.00	0.00	0.0%
6880 · Small Tools/Instruments	12,142.02	25,000.00	48.57%
6883 · Fire Equipment	0.00	0.00	0.0%
7000 · Tree Farm Expense	24,092.98	70,000.00	34.42%
7005 · Election Expense	224.00	15,000.00	1.49%
7120 · In-Service Training	5,849.87	15,000.00	39.0%
7150 · Recognition/Award	0.00	0.00	0.0%
7201 · Gas/Oil	8,608.77	12,000.00	71.74%
7300 · Transportation/Travel	745.57	5,000.00	14.91%
7303 · Private Car Expense	1,500.00	6,000.00	25.0%
7320 · Utilities	3,643.05	8,000.00	45.54%
60 · Supplies and Services - Other	76.64	0.00	100.0%
<b>Total 60 · Supplies and Services</b>	<u>201,525.86</u>	<u>458,241.00</u>	<u>43.98%</u>
66000 · Payroll Expenses	801.10	0.00	100.0%
66900 · Reconciliation Discrepancies	0.00	0.00	0.0%
75 · Other Charges			
7910 · Long-Term Debt - Principal	89,611.83	115,000.00	77.92%
7930 · Long-Term Debt - Interest			
Apparatus Debt - Principal	0.00	100,000.00	0.0%
7930 · Long-Term Debt - Interest - Other	83,079.27	100,000.00	83.08%
<b>Total 7930 · Long-Term Debt - Interest</b>	<u>83,079.27</u>	<u>200,000.00</u>	<u>41.54%</u>
8010 · Contribution Non-Co Govt	0.00	0.00	0.0%
75 · Other Charges - Other	0.00	0.00	0.0%
<b>Total 75 · Other Charges</b>	<u>172,691.10</u>	<u>315,000.00</u>	<u>54.82%</u>
86 · Other Financing Uses			
8620 · Unclaimed OT - Within A Fund	0.00	0.00	0.0%
86 · Other Financing Uses - Other	0.00	0.00	0.0%
<b>Total 86 · Other Financing Uses</b>	<u>0.00</u>	<u>0.00</u>	<u>0.0%</u>
999 · Undistributed	0.00	0.00	0.0%
<b>Total Expense</b>	<u>888,849.17</u>	<u>2,163,974.00</u>	<u>41.08%</u>
<b>Net Ordinary Income</b>	-828,964.11	121,156.00	-684.21%
Other Income/Expense			
Other Expense			

**Graton Fire Protection District**  
**Profit & Loss Budget vs. Actual**  
 July 1 through December 8, 2020

	<u>Jul 1 - Dec 8, 20</u>	<u>Budget</u>	<u>% of Budget</u>
85 · Capital Assets			
8510 · Buildings/Improvements	0.00	10,000.00	0.0%
8526 · Project Planning	0.00	0.00	0.0%
8560 · New Equipment	0.00	40,000.00	0.0%
85 · Capital Assets - Other	0.00	0.00	0.0%
<b>Total 85 · Capital Assets</b>	<u>0.00</u>	<u>50,000.00</u>	<u>0.0%</u>
9000 · To Review	0.00	0.00	0.0%
<b>Total Other Expense</b>	<u>0.00</u>	<u>50,000.00</u>	<u>0.0%</u>
<b>Net Other Income</b>	<u>0.00</u>	<u>-50,000.00</u>	<u>0.0%</u>
	<u><b>-828,964.11</b></u>	<u><b>71,156.00</b></u>	<u><b>-1,165.0%</b></u>



December 7, 2020

**VIA FIRST CLASS U.S. MAIL & EMAIL**

Graton Fire Protection District  
Bill Bullard, Fire Chief  
P.O. Box A  
Graton, CA 95444  
[bbullard@gratonfire.com](mailto:bbullard@gratonfire.com)

Re: Graton Fire Protection District Matters  
Gen. Bus.: Matter ID 3835-9584  
Policies & Procedures: Matter ID 3835-9587  
Pedro Chavez Discharge: Matter ID 3835-9588  
Jacobs-Public Records Act Request: Matter ID 3835-9589  
Conflict of Interest Statements: Matter ID 3835-9590  
New Fire Station: Matter ID 3835-9591  
2004-2007 General: Matter ID 3835-9592  
2009 General: Matter ID 3835-9593  
2010 General: Matter ID 3835-9594  
2011 General: Matter ID 3835-9595  
Graton v. Alvarez: Matter ID 3835-9796

Dear Chief Bullard:

On December 31, 2020, Bill Adams will be leaving our firm to become Of Counsel to the Law Firm of Johnston Thomas in Santa Rosa, California.

Inasmuch as Bill Adams worked on your matters, we wanted to inform you that you have the right to choose who you will continue to work with. Your files can remain with the firm, **or** you may elect to have the files transferred to the new firm with Bill Adams in his new capacity **or** you can choose to retain an entirely new lawyer or law firm. You do not need to do anything if your choice is to have Merrill, Arnone & Jones continue to represent you and have your files remain here. We will need written directions if you decide to have your files transferred to a new firm or to Mr. Adams.

If you wish to have Bill Adams **or** a new lawyer continue to represent you, you will still be responsible for paying your outstanding account with Merrill, Arnone & Jones for fees and costs for services already provided by the firm. Any retained or unspent fees or costs currently held by the firm will be promptly returned or transferred to Bill Adams or new lawyer as you designate.

LAW OFFICES

3554 ROUND BARN BLVD., STE. 303  
SANTA ROSA, CA 95403

(707) 528-2882 • FAX (707) 528-6015

E-mail: [firm@majlaw.com](mailto:firm@majlaw.com) • Website: [majlaw.com](http://majlaw.com)

Graton Fire Protection District  
December 7, 2020  
Page 2

Please advise Merrill, Arnone & Jones, of your decision so that continuity in your representation is assured. You do not need to do anything if you will be remaining with the Firm. However, you may do otherwise by indicating your choice to have the files and matters moved below and returning a signed and dated copy of the below form by regular mail or by email to our office administrator, Paula Johnson, at [pjohnson@majlaw.com](mailto:pjohnson@majlaw.com), and Bill Adams, at [wadams@majlaw.com](mailto:wadams@majlaw.com). Please retain the additional copy of this designation letter for your records.

Yours truly,

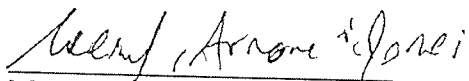
  
Merrill, Arnone & Jones, LLP

  
Bill Adams

Board of Directors  
Graton Fire Protection District  
P.O. Box A  
Graton, CA 95444

November 6, 2020

Vine Hill Vistas Mutual Water Co., Inc. ("VHV") requests an exemption from the Graton Fire Special Tax property tax.

VHV owns four (4) parcels that provide locations for our two wells, a backup well-site and our storage tanks and pump with the following parcel numbers: 078-140-028-000, 078-140-029-000, 078-140-030-000, and 078-140-091-000.

As noted on the map below, these are extremely small parcels relative to the surrounding lots – three (3) of them are under 1,000 square feet, one of which is about 300 square feet.

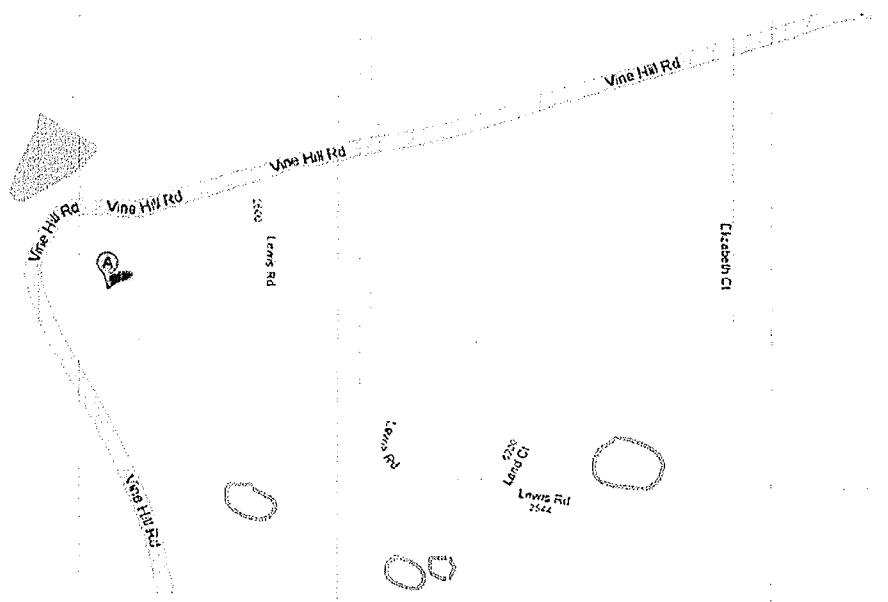

As shown in the attached property tax bills from Sonoma County each parcel has a net assessed value of \$0.00 resulting in \$0.00 of property tax. However, each was billed the \$100 per parcel Graton Fire Special Tax for a total cost of \$400 for the 2020-21 fiscal tax year.

According to the ballot measure of 2019: "All property that would otherwise be exempt from property tax will also be exempt from the proposed tax". It is our position that the \$0.00 net assessment and \$0.00 property tax from Sonoma County makes our parcels functionally exempt from property tax and therefore they should also be exempt from the Graton Fire Special Tax.

Please grant our request for an exemption from the Graton Fire Special Tax for all 4 parcels.

Thank you.

Sincerely,

A handwritten signature in black ink, appearing to read "Tim DuPertuis", with a long horizontal flourish extending to the right.

Tim DuPertuis  
President, Board of Directors  
2515 Lewis Drive  
Sebastopol, CA 95472  
707-829-2270  
timdp@sonic.net

Graton Fire Department,

130-080-026: Parcel in question

130-080-025: 4482 Ross Rd, main/only residence

We purchased this property in 2015, and while aware of the 2<sup>nd</sup> parcel, we have never received a property tax bill as its value is sooo little. I havnt understood why there are 2 parcels but it didn't really make a difference.

This year we received a bill for \$100, while also paying the \$250 on the house. I'm writing to ask for the fee on 130-080-026 to be forgiven & removed this year. We are going to request to county to merge these 2 parcels together and it seems there shouldn't be any issue with that (we are waiting to receive the application).

I have always been very thankful to have a fire station - and a great one at that - so close! I understand funding is very important to keep things going strong. However, this year has also been a hard one for many - myself included - and any bill I can save on is very helpful.

I appreciate you taking the time to read this letter and I hope you can consider removing the fee. I'm sure you'll see on the map how this parcel overlaps 4482 Ross Rd and can see why I'm requesting this.

Thank you (everybody at the station!)  
for all you do 24/7/365!

Kindly,  
Co owner Brooke Reeder

Janey Mughannam 707-293-7484



▼ 130-080-026 X Q

Show search results for 130-08...

Map Details & Legend

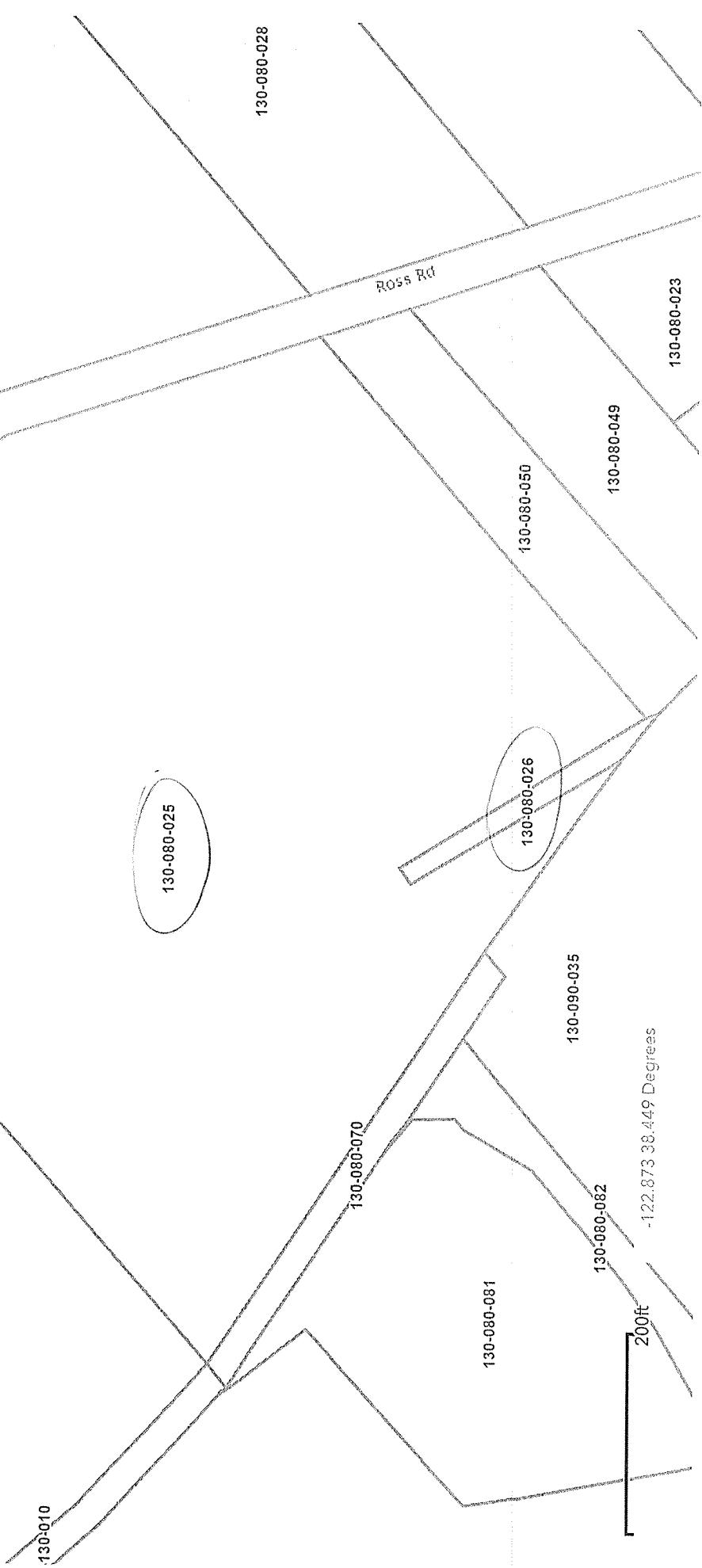



# Graton Fire Protection District

Post Office Box A, Graton, California 95444

www.gratonfire.com

## ROSTER

#	Name	Rank	CDL	Cell	Home	Wk/Pgr/Other
1	Bill Bullard	8400 Chief / EMT	B	292-7286	887-8484	
2	Scott Fisher	8401 Deputy Chief	B	529-4483	829-9344	
3	Robert Sabrowsky	8402 Asst Chief / EMT	B	486-8481	823-5725	
4	<b>Josh Skikos</b>	<b>8403 Asst Chief</b>	<b>C</b>	<b>529-0383</b>	<b>829-4522</b>	<b>W</b>
5	Darrell Kopriva	8404 Captain	C+	486-3775	536-9992	W 576-1371
6	Ian Muskar	8405 Captain / EMT	A	396-1147		
7	Lindsay Cruckshank	8406 Captain	C+	696-6049	869-5616	W 823-1542
8	Jason Gray	Engineer / EMT	A	236-2605		
9	Dustin Blumenthal	Engineer / EMT	C+	490-2626		
10	Kyler Walker	Engineer / EMT	B	328-8234		
11	Dusty Parker	Engineer / EMT	B	953-0581		
12	Ed Miranda	Firefighter	C	483-0391		
13	Zach Colenzo	Firefighter	C	292-9739		
14	Shane Spelman	Firefighter / EMT	C+	494-0929	829-1934	
15	Jonathan Preciado	Firefighter / EMT	C	480-5010		
16	Matt Skinner	Firefighter	C+	530-680-1046		
17	Jacob Mual	Firefighter / EMT	C	721-4817		
18	Matt Miller	Firefighter / EMT	C	569-6301		
19	Levi DeCarly	Firefighter / EMT	C	483-3280		
20	Chaz Mathias	Firefighter	C	480-0213		
21	Kyle Bartlett	Firefighter / EMT	C+	490-6077		
22	Ryan Fernandez	Firefighter / EMT	C	332-6585		
23	Jenna Dunbar	Firefighter	C	805-400-8589		
24	Amanda Roy	Firefighter / EMT	C	495-3055		
25	Chris Lomanto	Firefighter	C	888-1057		
26	Ben Miller	Firefighter / EMT	B	326-1610		
27	Sam Ballenger	Firefighter	C	393-9080		
28	Jeremiah Mahan	Trainee / EMT	C	217-1484		
29	Jennifer Gehrman	Trainee	C	209-743-2248		
30	Kristen Cattell	Trainee	C	799-2432	823-8454	
31	Emily Fuller	Trainee	C	799-7848		
32	Mathias Bonse	Trainee	C	326-5694		W 577-4732
33	Lia Liskey	Trainee	C	326-1969		W 721-4402
34	<b>Derek Towne</b>	<b>Trainee</b>	<b>A</b>	<b>396-2315</b>		
35	Evan Jacobs	Cadet	L	490-9491	829-1161	
36	Maci Farmer	Cadet		495-8244		
	Bob Maddocks	President		888-4020	823-9575	
	Torrey Farmer	Vice President		495-7123		
	Mario Cesaretti	Treasurer		591-5600	823-9400	
	Wes Gray	Secretary		953-1409	823-5812	
	Jason Nunes	Member		849-1311		
GFPD Business Phone Number 823-8400						
GFPD Fax Number 823-7251						
Graton Firefighters Association Phone Number 823-8400 x120						
Graton Fire Tree Farm/Heather O'Dell 322-2091						
Graton Fire Investigator/John Teague 483-1433						



# Graton Fire Protection District

Post Office Box A, Graton, California 95444

www.gratonfire.com

## ANNUAL ALARMS 2020-2021

Type	JUL	AUG	SEP	OCT	NOV	DEC	JAN	FEB	MAR	APR	MAY	JUN	Totals
Assist/Service Call		6	1	2									9
Auto/Mutual Aid	14	16	14	12	2								58
Debris Fire		1											1
Fire Alarm	3	2	1	3	2								11
Gas Leak													0
Hazardous Condition	4	2	5	3	2								16
Haz-Mat			1										1
Investigation	6	10	2	4	2								24
Medical Aid	27	22	19	28	28								124
Other / Cancellations													0
Rescue													0
Structure Fire		1		1									2
Traffic Collision	2	6	3	3	3								17
Vegetation Fire	1	2		3									6
Vehicle Fire	1		1	1									3
<b>Total</b>	<b>58</b>	<b>68</b>	<b>47</b>	<b>60</b>	<b>39</b>	<b>0</b>	<b>0</b>	<b>0</b>	<b>0</b>	<b>0</b>	<b>0</b>	<b>0</b>	<b>272</b>

Prepared By: Capt. Darrell Kopriwa





# Graton Fire Protection District

Post Office Box A, Graton, California 95444

[www.gratonfire.com](http://www.gratonfire.com)

## Drill & Activity Reports

## NOV 2020

#	Date	Description	Type
1)	11/05	Rapid Intervention (RIC)	R
2)	11/10	Engineers Meeting	S
3)	11/12	Town Hall Meeting/New Hose Load Training	R
4)	11/19	Auto Extrication (Cream's)	R
5)	11/20	Fire Academy (Building Construction)	T
6)	11/21	Fire Academy (Hose Load Evolutions)	T
7)	11/25	Scene Lighting/X-Mas Tree Unloading	R
8)	11/27	Fire Academy (Chainsaws)	T
9)	11/27	Fire Academy (Fire Behavior)	T
10)	11/28	Fire Academy (Ladders)	T

(DW) Duty Weekend  
(R) Regular Drill  
(S) Special Drill  
(T) Trainee Drill

Prepared By: Capt. Darrell Kopriva